



## Selection: Semi-hermetic Screw Compressors HS

### Input Values

Compressor model	HSN7471-75	Operating mode	Economiser
Refrigerant	R404A	Power supply	400V-3-50Hz
Reference temperature	Dew point temp.	Useful superheat	100%
Liq. subc. (in condenser)	0 K	Additional cooling	Automatic
Auto. subcooling	Auto	Max. discharge gas temp.	80,0 °C
Suct. gas superheat	10,00 K		

### Result

Q [W]	Cooling capacity	mHP [kg/h]	Mass flow HP
P [kW]	Power input	Qac [kW]	Additional cooling
I [A]	Current	tcu [°C]	Liquid temp.
COP [-]	COP/EER	pm [bar(a)]	ECO pressure
mLP [kg/h]	Mass flow LP	Qsc [kW]	sub cooler capacity (ECO)

tc	to	-15°C	-20°C	-25°C	-30°C	-35°C	-40°C	-45°C	-50°C
<b>30°C</b>	Q [W]	155803	130851	108992	89904	73290	58881	46437	35745
	P [kW]	54,8	52,5	50,2	48,0	45,8	43,5	41,2	38,9
	I [A]	87,9	84,4	81,0	77,7	74,3	71,0	67,6	64,3
	COP [-]	2,84	2,49	2,17	1,87	1,60	1,35	1,13	0,92
	mLP [kg/h]	3934	3262	2678	2174	1741	1372	1059	797
	mHP [kg/h]	4496	3852	3274	2757	2296	1886	1522	1200
	Qac [kW]	--	--	--	--	--	1,97	6,60	10,66
	tcu [°C]	16,80	13,48	9,91	6,07	1,94	-2,49	-7,22	-12,27
	pm [bar(a)]	7,46	6,74	6,03	5,32	4,64	3,98	3,36	2,78
	Qsc [kW]	21,1	21,9	21,8	21,0	19,63	17,80	15,65	13,28
<b>40°C</b>	Q [W]	143059	120301	100363	82931	67723	54493	43027	--
	P [kW]	65,9	63,3	60,7	58,1	55,5	53,0	50,7	
	I [A]	104,5	100,5	96,6	92,7	88,9	85,2	81,7	
	COP [-]	2,17	1,90	1,65	1,43	1,22	1,03	0,85	
	mLP [kg/h]	3857	3193	2616	2119	1693	1330	1023	
	mHP [kg/h]	4689	4027	3432	2899	2422	1996	1616	
	Qac [kW]	--	--	--	3,53	8,42	12,96	17,14	
	tcu [°C]	22,9	19,44	15,72	11,67	7,29	2,56	-2,53	
	pm [bar(a)]	8,91	8,07	7,22	6,37	5,54	4,74	3,98	
	Qsc [kW]	28,3	28,0	26,9	25,3	23,1	20,6	17,88	
<b>50°C</b>	Q [W]	126532	106501	88886	73397	59782	47825	37344	--
	P [kW]	80,0	77,1	74,2	71,3	68,5	66,1	64,0	
	I [A]	125,7	121,3	116,9	112,5	108,4	104,7	101,6	
	COP [-]	1,58	1,38	1,20	1,03	0,87	0,72	0,58	
	mLP [kg/h]	3710	3059	2494	2006	1587	1230	928	
	mHP [kg/h]	4839	4164	3555	3006	2510	2062	1657	
	Qac [kW]	9,20	13,85	18,17	22,2	26,2	30,0	33,9	
	tcu [°C]	29,9	26,3	22,3	17,97	13,19	7,96	2,24	
	pm [bar(a)]	10,85	9,82	8,78	7,72	6,68	5,66	4,69	
	Qsc [kW]	34,1	32,8	30,9	28,5	25,6	22,4	19,01	

-- No calculation possible (see message in single point selection)

\*According to EN12900 (10K suction gas superheat, liquid subcooling in Economiser with 5K temperature difference)

## Application Limits ECO HSN7471-75

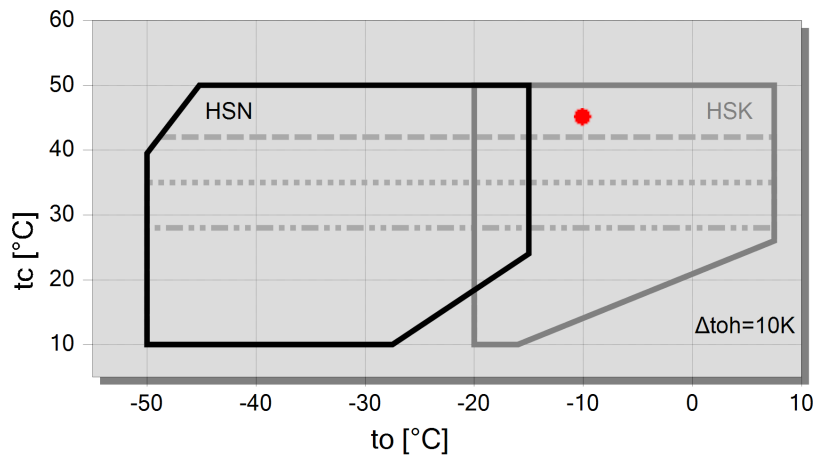

**Legend**

- max.  $t_c$  for frequencies = 20Hz
- ..... max.  $t_c$  for frequencies = 25Hz
- max.  $t_c$  for frequencies = 35Hz
- A



## Technical Data: HSN7471-75

### Dimensions and Connections

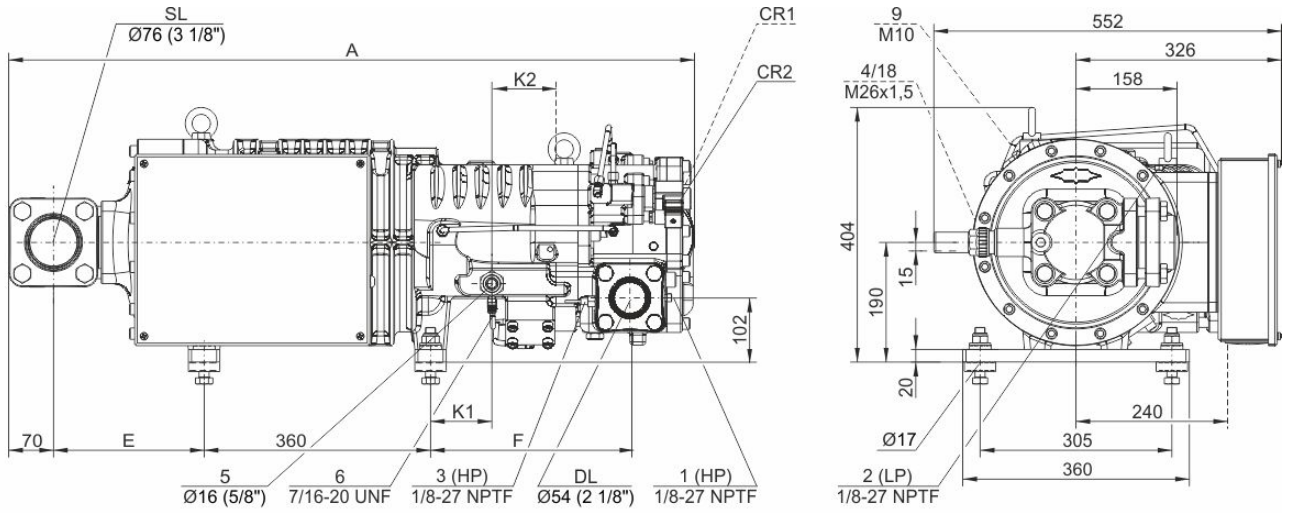

Model	A	E	F	K1	K2
	mm	mm	mm	mm	mm
HS.7451, HS.7461	1021	186	295	76	109
HSK7471-70, HSN7471-75	1034	186	318	98	97
HSK7471-90	1087	238	318	98	97



## Technical Data

### Technical Data

Displacement (2900 RPM 50 Hz)	250 m <sup>3</sup> /h
Displacement (3500 RPM 60 Hz)	302 m <sup>3</sup> /h
Weight	326 kg
Max. pressure (LP/HP)	19 / 28 bar
Connection suction line	76 mm - 3 1/8"
Connection discharge line	54 mm - 2 1/8"
Adapter/shut-off valve for ECO	22 mm - 7/8" (Option)
Oil type R22	B150SH, B100 (Option)
Oil type R134a/R404A/R507A/R407A/R407F	BSE170
Oil type R448A/R449A/R454C	BSE170

### Motor data

Motor version	1
Motor voltage (more on request)	380-415V PW-3-50Hz
Max operating current	144.0 A
Starting current (Rotor locked)	350.0 A D / 585.0 A DD
Max. Power input	85,0 kW

### Extent of delivery (Standard)

Discharge gas temperature sensor	Standard
Start unloading	Standard
Oil flow control	SE-B3 (Standard)
Motor protection	SE-E1 (Standard), SE-E3 (Standard for 660-690V)
Suction shut-off valve	Standard
Capacity control	100-75-50% (Standard)
Enclosure class	IP54

### Available Options

Discharge shut-off valve	Option
ECO connection with shut-off valve	Option
Motor protection	SE-i1 (200-690V)

### Sound measurement

Sound power level (-35°C / 40°C)	87,5 dB(A)
Sound pressure level @ 1m (-35°C / 40°C)	79,5 dB(A)



## Semi-hermetic Screw Compressors HS

**HSK** = Application for air-conditioning and medium temperature cooling.

**HSN** = Application for low temperature cooling.

### Notes regarding application limits (see "Limits")

- \* Ranges are valid for standard operation and at full-load conditions.
- \* With high pressure conditions, part-load operation is partly limited (see application limits in applications manual SH-100).
- \* With Economizer operation the maximum admissible evaporation temperature is shifted by 10K downward (otherwise there is a danger of excessive compression and overload of the motor because of a higher mass flow). At pull-down conditions from higher evaporation temperatures, the ECO injection must remain closed until the evaporation temperature is below the maximum admissible value and a stable operation is achieved (e.g. control of the ECO solenoid valve by means of a low pressure cut-out). The use of the ECO-system with higher evaporation temperatures requires individual consultation with Bitzer.

### HS 64/74

- \* Capacity control with ECO operation at the same time is limited to one single regulating step (CR 75%). At CR 50% the ECO injection should be closed.

### Data for sound emission

Data are based on 50Hz application (IP-units 60Hz) and R404A.

Sound pressure level: values are based on open air test sites with semi-spherical sound emissions at 1 meter distance. For further information see Technical Information "Sound Data".

### Legend of connection positions according to "Dimensions":

- 1 High pressure connection (HP)  
Connection for high pressure switch (HP)
- 1a Additional high pressure connection (HP)  
Not suitable for pressure switch or pressure transmitter!
- 1b Connection for high pressure transmitter (HP)
- 2 Low pressure connection (LP)  
Connection for low pressure switch
- 2a Additional low pressure connection (LP)
- 2b Connection for low pressure transmitter (LP)
- 2c Low pressure connection for the minimum pressure differential control valve
- 3 Connection for discharge gas temperature sensor (HP)
- 4 Connection for economiser (ECO)  
HS.85: ECO valve with connection line (option)  
OS.85, OS.95, OS.105, HS.95: ECO valve (option)
- 5 Connection/valve for oil injection
- 6 Oil pressure connection
- 7 Oil drain (compressor or motor housing)
- 7a Oil drain (suction gas filter)
- 7b Oil drain from shaft seal (maintenance connection)
- 7c Oil drain hose (shaft seal)
- 8 Threaded bore for foot fastening
- 9 Threaded bore for pipe fixture (ECO and LI lines)
- 10 Maintenance connection for oil filter
- 11 Oil drain (oil filter)
- 13 Oil filter monitoring
- 14 Oil flow switch
- 15 Earth screw for housing
- 16 Pressure blow-off (oil filter chamber)
- 17 Maintenance connection for shaft seal
- 18 Liquid injection (LI)
- 19 Compressor module
- 20 Slider position indicator
- 21 Oil level switch
- 22 Oil pressure transmitter



- 23 Connection for oil and gas return (for systems with flooded evaporator adaptor optional)
- 24 Access to oil circulation restrictor
- 25 Oil inlet for shaft seal cooling
- 26 Oil outlet for shaft seal cooling
- 27 Temperature sensor in the shaft seal
- 28 Vibration sensor connection
- SL Suction gas line
- DL Discharge gas line

Dimensions can show tolerances according to EN ISO 13920-B.